

ATC-lab^{Advanced}

Participant Training Manual

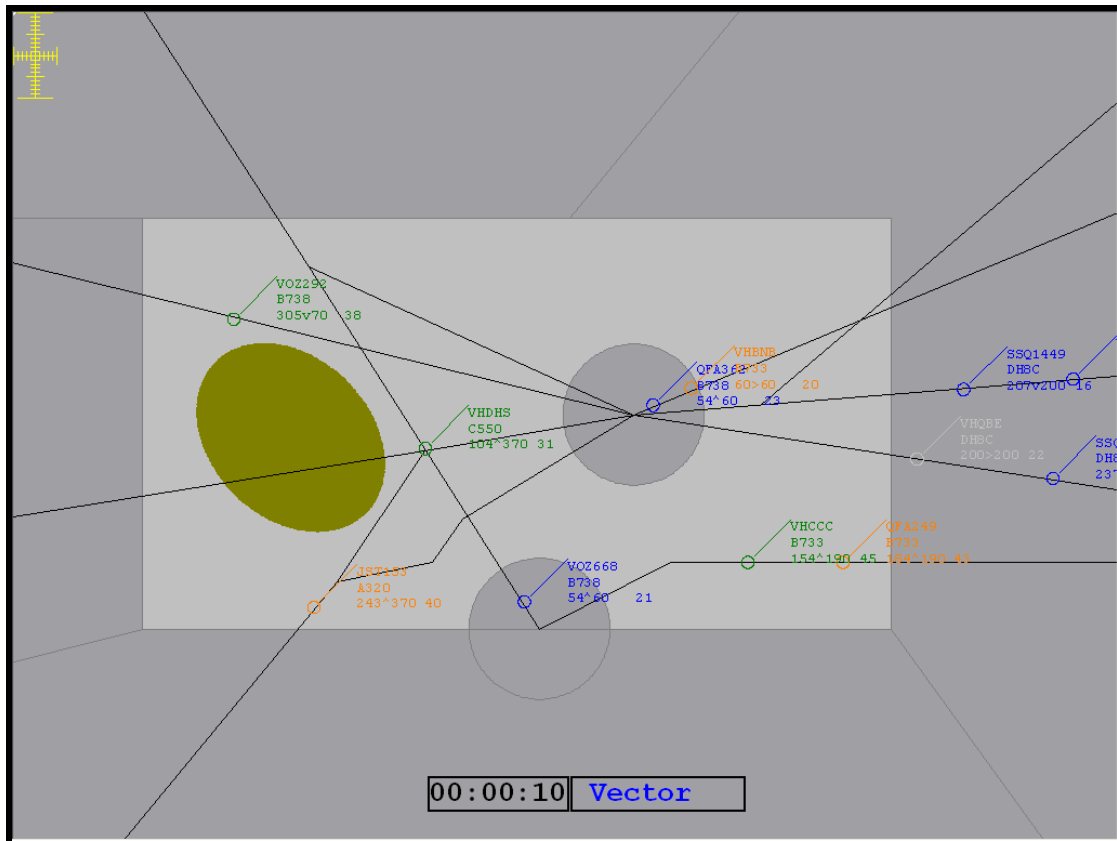

Change History		
Date	Version	Authors
11.12.06	1.0	Selina Fothergill
10.01.06	2.0	Selina Fothergill Andrew Neal
20.07.08	3.0	Selina Fothergill Andrew Neal

Table of Contents

Introduction.....	4
Purpose of this Booklet.....	4
Further Information.....	4
Experiment Tasks.....	5
About these Tasks	5
Task 1 Scenarios	5
Task 2 HMI and Map.....	5
Task 3 Tools.....	5
Task 4 Cruise and Descent.....	5
Task 5 Questions.....	5
Task 6 Resolutions.....	5
Task 1 Moving through the Scenarios	6
Handover.....	6
Next Scenario.....	6
Task 2 ATC-lab HMI Interaction and Maps.....	7
Using the Mouse	7
Aircraft Labels	7
Flight Strips.....	8
Maps.....	9
Routes and Way Points	9
Weather	10
Sectors.....	10
Approach.....	10
Task 3 Tool Use	11
Bearing and Range Line.....	11
Route	11
Scale Use.....	11
Label Movement	12
Probe Vectors.....	12
Turning the tools OFF!!.....	12
Mode and Clock.....	14
Left Clicks.....	14
Task 4 Accepting and Handing off, Assigning Cruise, Sector Limits and Descents...	15
Accept an Aircraft.....	15
Handoff an Aircraft.....	15
Sector Boundaries	15
Jet Aircraft	16
Turbo Propelled Aircraft.....	16
Task 5 Answering Questions	17
Mental Workload	17
Task 6 Resolution Options.....	18
Level Change	18
Speed Change.....	18
Level Requirement by Distance.....	19
Vector.....	19
Step Climb or Descent	20
Instructions and Coordination.....	20

Left Clicks.....21
Notes22

Introduction

Purpose The purpose of this booklet is to train you how to use this simulator, so that you can participate in the experiment. The simulator software package is called ATC-lab^{Advanced}. Although the software resembles the regular Australian Air Traffic Control (ATC) environment, it has not been designed to simulate the software itself. Rather it was developed to provide ATC tasks as stimulus in experimental research.

Due to the differences between the real ATC software and this software package, a short training course has been developed to assist you in learning the tools for operating ATC-lab^{Advanced}.

The booklet is designed to equip you with the skills needed to:

- Use various tools.
 - Implement solutions to potential conflicts.
 - Perform other ATC tasks such as accepting or handing off aircraft.
 - Answer any questions that you may have about the experiment.
-

Further Information If you have any questions about the experiment or the software being used, please contact your experimenter.

Experiment Tasks

About these Tasks These training tasks are designed to familiarise you with the software so that you can participate in the experiment. There will be a series of six short tasks for you to complete. These will give you practise at using the tools, implementing resolutions to potential conflicts, issuing descents and cruise levels and accepting or handing off aircraft. You will also get a chance to get used to moving through the scenarios and answering questions throughout the experiment.

Task 1 Scenarios The aim of this task is to demonstrate how the experimenter will move through the scenarios. Each time a new scenario is presented to you, the experimenter will pause the aircraft on the screen and give you a simple handover briefing before you commence your management of the airspace.

Task 2 HMI and Map The aim of this task is to demonstrate how you will use the mouse to interact with aircraft and tools on the screen. Routes, way points, adjacent sectors and approach sectors will also be explained.

Task 3 Tools The aim of this task is to familiarise yourself with the tools available to you. These include moving aircraft labels around, moving the scale, using the range and bearing line, using minute probe vectors and viewing the route.

Task 4 Cruise and Descent The aim of this task is to familiarise yourself with issuing descents, climb and cruise levels. It will also give you practise at accepting aircraft and handing them off to the next sector.

Task 5 Questions The aim of this task is familiarise you with questions that may be asked while you are managing the airspace. Questions about the workload level you are experiencing are used as an example.

Task 6 Resolutions The aim of this task is to familiarise yourself with using the resolutions that you have available to you. These include issuing level changes, changing headings, issuing speeds, step climbs and descents and setting requirements to be at a level by a certain distance.

Task 1 – Moving through the Scenarios

Handover At the commencement of each scenario the experimenter may pause the traffic and give you a brief handover of what is occurring in the airspace before you begin.

Next Scenario Some time into the scenario, the experimenter will tell you it has concluded and will introduce the next scenario. Again the experimenter may pause the scenario before you begin to give you a handover briefing.

Depending on your experiment, the scenarios may not play out to their completion. That is, you may not get the opportunity to monitor all of the aircraft as they fly in and out of your screen view. The experimenter may only be interested in one specific task in each scenario and after it has passed they will move on to the next scenario. As a result you may not be able to solve all of the conflicts or accept/handoff all of the aircraft before the experimenter moves you on to the next task. Despite this, please treat each scenario as a realistic situation. Consider it as real traffic that needs to be continuously monitored. The ending of the task is artificial.

The experimenter will show you these functions now. He/She will begin a scenario and then pause it to give an example handover. Then he/she will recommence the scenario, move on to another scenario and finally exit the program.

Task 2 – ATC-lab HMI Interaction and Maps

Using the Mouse

Throughout the experiment you will be using a mouse to interact with the aircraft on the laptop screen and also use the tools. The mouse is a regular optical wheel mouse. It has a right and a left button plus a scroll function. For all functions used in the experiment you will only need to use the *LEFT* mouse button.



This is the mouse you will be using to interact with the airspace.

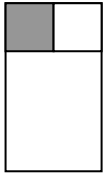

The *LEFT* button of the mouse is used for all tool functions, handovers, acceptances, level issuing and resolutions.



This is the pointer for the mouse that you will see on the screen.

Please note that using the mouse in this way will be more similar to operating a regular computer than what you are used to in TAAATS.

Aircraft Labels

Attached to the track symbols for each aircraft is certain information about the flight. The label information that you will see for an aircraft includes their radio callsign, the aircraft type, their current flight level, their assigned flight level and their current speed. Flight levels in the labels will indicate that the aircraft is either on climb, on descent or maintaining that flight level.

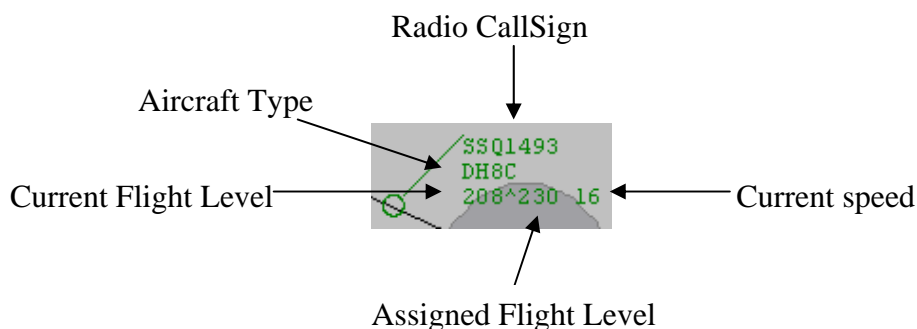

Task 2 – ATC-lab HMI Interaction and Maps, Continued

Similar to the real ATC system, different colours are used to represent aircraft in their different phases of flight. These are as follows:



GREEN: Aircraft under your jurisdiction

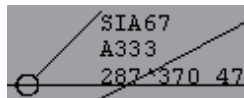

BLACK: Aircraft in another sector not under your jurisdiction

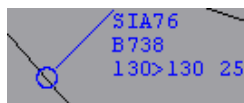

BLUE: Announced aircraft



SALMON: Aircraft leaving your sector



FLASHING SALMON: Aircraft coming in to your sector

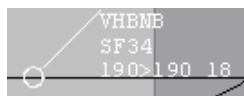

WHITE: Aircraft has been handed off and accepted by the next sector

Flight Strips

You will also have a list of paper flight strips beside you to provide you with information about each flight. You will probably only need to refer to these when assigning aircraft cruise altitudes.

There will be two sets of flight strips for each scenario. The first are for aircraft on descent. These are displayed first and will look like this:

 MAP1	VOZ324 1000 B738 M APPROACH1		000 300	EAST 0300 000	APPROACH1 000

Task 2 – ATC-lab HMI Interaction and Maps, Continued

The second set of flight strips for the scenario are for aircraft on climb. These are displayed second and will look like this:

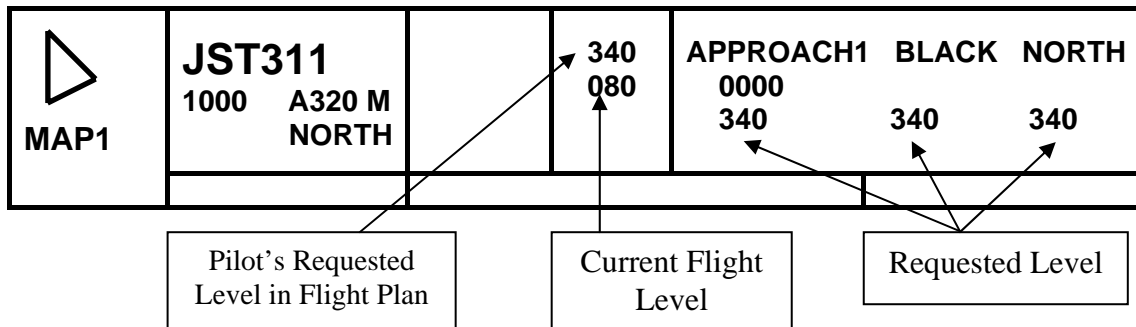

Part	Description
JST311	This is the radio callsign of the aircraft
MAP1	This is the map being used
1000	This is a time stamp
A320 M	This is the aircraft type (An Airbus 320 Medium aircraft)
NORTH	This is the destination
APPROACH1	This is the origin
BLACK	This is a Way Point

Note that there may not be many way points listed on the flight strips, as they are short paper strips. Flight Strips mostly indicate where an aircraft commenced its flight and which sector it is heading towards.

Maps

There may be different maps used in this experiment for the scenarios. Your experimenter may provide you with these maps throughout the experiment to refer to. Maps can vary in terms of the routes and the number of sectors. Some of the scenarios may also have weather patterns and way points placed on the tracks.

Routes and Way Points

The routes and way points can change on each map.

Waypoints are represented by a black circle with the way point name in blue writing.



Task 2 – ATC-lab HMI Interaction and Maps, Continued

Weather

If weather appears on your maps, generally aircraft cannot fly through these patterns.



Sectors

There are two types of sector in this experiment. The sector you are controlling which is coloured in a lighter shade of grey and adjacent sectors (e.g., North, West, East and South) coloured in a darker shade of grey.

Your Sector 

Adjacent Sectors 

Each sector also has its own frequency. Your experimenter may wish you to refer to them as follows:

Sector	Frequency
GENERIC (yours)	0.00
NORTH	360.00
WEST	270.00
EAST	90.00
SOUTH	180.00

Approach

If approach sectors are used in the experiment, they are represented by a circle and are shaded in the same grey as adjacent sectors. While you will most likely be expected to manage traffic in your own sector and handoff aircraft to approach, you may not need to manage aircraft within the approach sector.

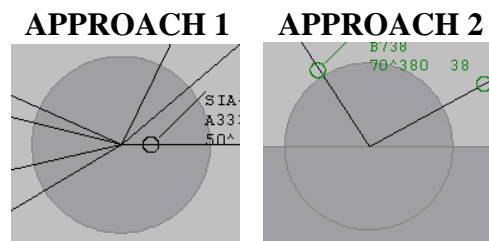

When handing aircraft off to approach you may refer to the sector as 'Approach' (E.g., "Contact Approach 1").

Please take some time to study the maps and Flight Strips before starting the experiment.

Task 3 – Tool Use

Bearing and Range Line

The bearing and range line shows the distance between two points (in nautical miles), the bearing and the time (in minutes) it will take for an aircraft to get to the selected end point.

You will see: A fluorescent green line from where you dragged the cursor to where you ended it. At the end of the line will be a green cross and square with the distance, bearing and time information in it.

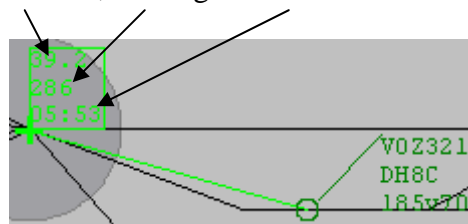

Note that time is calculated as distance/airspeed and is not used if both ends are attached to aircraft.

Route

The planned route for an aircraft can be switched on to see where the aircraft is heading.

You will see: A yellow line showing the path the aircraft will follow punctuated by the times it will take for the aircraft to reach each point along the way.

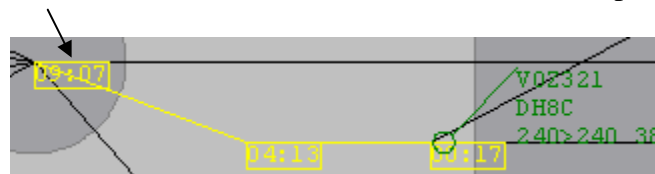

Scale Use

The scale can be moved around the screen with your mouse to measure distances.

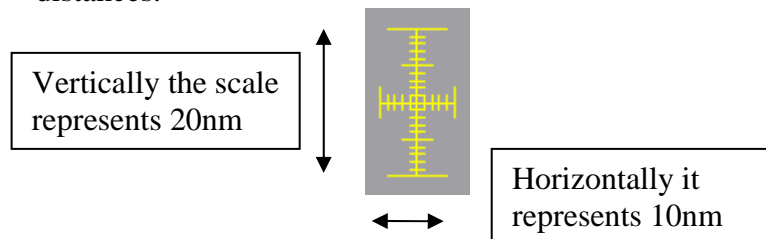

Task 3 – Tool Use, Continued

Label Movement You are able to move aircraft labels around to give yourself a clearer picture of all the aircraft in your airspace.

Labels can move around to four different positions.

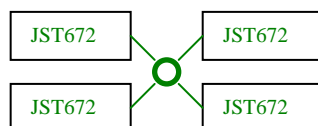

Probe Vectors Probe vectors can be used to project where the aircraft will be in a certain number of minutes. You can repeatedly click on the aircraft to get probes for 1, 2, 3, 5, 10 and 15 minute vectors.

You will see: A line in the same colour as the aircraft label extend from the aircraft for the number of minutes asked for.



You may also like to turn on the 1 minute probe vectors to remind yourself of the direction of each aircraft.

Turning the Tools OFF!! The tools can also be turned off after you use them by pressing the ESCAPE key. This is an important thing to remember as if you do not switch them off and then begin using a new tool or try to move a label around for another aircraft, the tool you were previously using will come up unwanted!!

Task 3 – Tool Use, Continued

Mode When using a tool, implementing a solution or accepting an aircraft, it will be displayed in the box in the centre of the bottom of the screen. In the example below, the short route probe has been turned on for VOZ668 so it is displayed in the box.

Clock The display also has a clock in the centre of the bottom of the screen. It will begin at zero at the beginning of each scenario. If the time shown is **BLACK**, it is running. If the time shown is **RED**, it has stopped. In the example below the scenario is running and has played out for 10 seconds (note that your clock may run at a different time to regular seconds – such as double the speed – to represent aircraft movement more accurately).

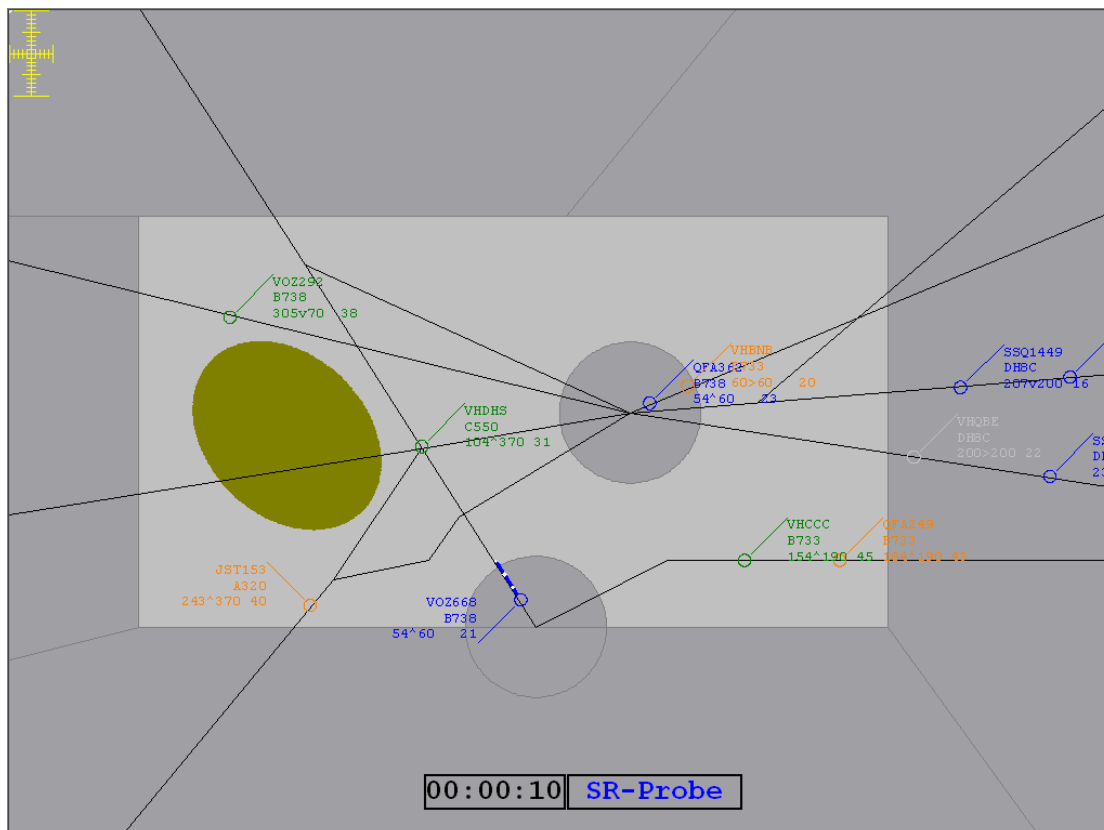

Task 3 – Tool Use, Continued

Left Clicks

Function	Turning the Tool ON	Turning OFF the Tool for the Aircraft	Turning OFF the Tool completely !!
Bearing and Range Line	B and CLICK Press B and click on the track symbol for the aircraft, hold and drag the line to the end of the distance you want to measure	DOUBLE CLICK GREEN SQUARE	CLICK ESCAPE
Display Route	R and CLICK Press R and click on the track symbol for the aircraft	CLICK AIRCRAFT	CLICK ESCAPE
Scale Use	CLICK and DRAG Click on the scale, hold and drag it to where you want on the screen		
Moving a Label	DOUBLE CLICK Double click on the track symbol Repeat until the label is readable		
Probe Vectors	P and CLICK Press P and click on the track symbol for the aircraft between 1 and 6 times to show 1, 2, 3, 5, 10 or 15minute vectors	CLICK through all VECTORS Click through all probe vectors, then click again	CLICK ESCAPE

Your experimenter will now guide you through implementing each of these tools in sequence on aircraft in a practise scenario.

Be sure to ask any questions if you have any!

Task 4 – Accepting and Handing off, Assigning Cruise, Sector Limits and Descents

Accept an Aircraft

You can accept an aircraft from an adjacent sector or Approach.

You will see: The aircraft and its label will change from flashing SALMON to GREEN.

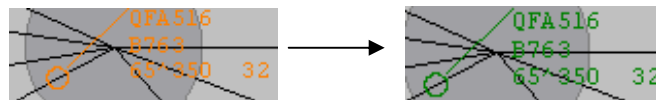

Handoff

Aircraft will automatically be accepted by the next sector.

You will see: When approaching the next sector the aircraft label will be SALMON. When it has been accepted the label will change to WHITE.

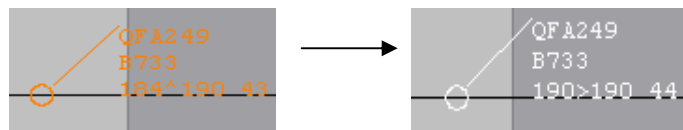

Instruction	Action
Accept an Aircraft	Y and CLICK Press Y and click on the track symbol for the aircraft
Handoff	AUTOMATIC

Sector Boundaries

Certain levels may need to be assigned and reached before crossing sector boundaries. For example, your experimenter may expect:

- Aircraft will enter your sector from sector EAST **on descent**.
- Aircraft will enter your sector from sectors NORTH, WEST and SOUTH at **cruise** altitudes.
- Aircraft entering your sector from approach will have been assigned **A060**.
- When aircraft going to sector EAST arrive in your sector from approach they can be assigned **cruise**.
- When aircraft come arrive in your sector they need to be assigned **A070** and to reach that level before entering Approach.
- When aircraft going to sectors NORTH, WEST or SOUTH enter your sector from an Approach, they can be assigned their **cruise** altitudes.

Task 4 – Accepting and Handing off, Assigning Cruise, Sector Limits and Descents, Continued

The map below illustrates these example sector boundary levels.

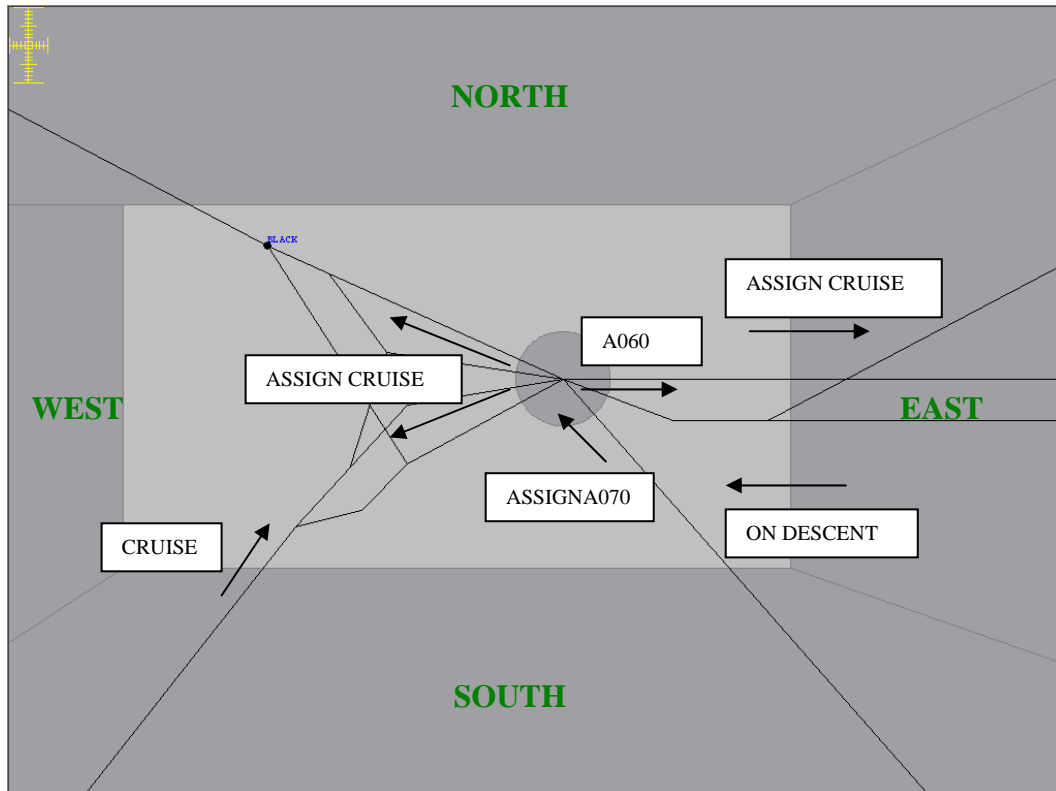

Jet Aircraft If used, Top of Descents for Jet aircraft will be marked on the maps that you will have beside you.

Turbo Propelled Aircraft Top of Descents for Turbo Propelled aircraft would also be marked on the map that you will have beside you.

Because there is no acting pilot in the experiment, all descents issued will begin immediately rather than 'When Ready'.

Please study where Top of Descents need to be issue for Jet and Turbo Propelled aircraft. The Experimenter will now give you some example scenarios to practise accepting and handing off aircraft as well as assigning the appropriate levels.

Task 5 – Answering Questions

Mental Workload

You may be asked to answer questions throughout the experiment. As an example, you may be asked to rate the workload level in 1 minute intervals. This question is asking how high you would rate the workload level you are currently experiencing.

The aim of this question is to obtain an accurate evaluation of controller workload. Workload refers to all the physical and mental effort that you must exert to do your job. This includes maintaining the “picture”, planning, coordinating, decision making, communicating, and whatever else is required to maintain a safe orderly and expeditious traffic flow.

Using the scale below, you may be asked to call out your current workload rating whenever the question is verbally asked. The scale will be beside you during the experiment to refer to.

The question may be phrased: “How hard were you working over the past minute?”

WORKLOAD:									
1	2	3	4	5	6	7	8	9	10
Low Workload		*Moderate Workload*			*High Workload*			*Extreme Workload*	
Could accomplish everything easily.		Could accomplish everything, but took some effort.			Difficult to accomplish everything, but did not need assistance.			Extremely difficult to accomplish everything. Assistance was required.	

Note that you may find being repeatedly asked questions quite frustrating, as you will be managing traffic at the same time. The experiment however, may be designed to examine the effect of certain variables like workload, so it would be essential to record this.

Task 6 – Resolution Options

Level Change

You can change the Flight Level of an aircraft in intervals of 1000ft.

You will see: A list of possible Flight Levels will pop up for you to choose from. The aircraft label will read the new chosen level.

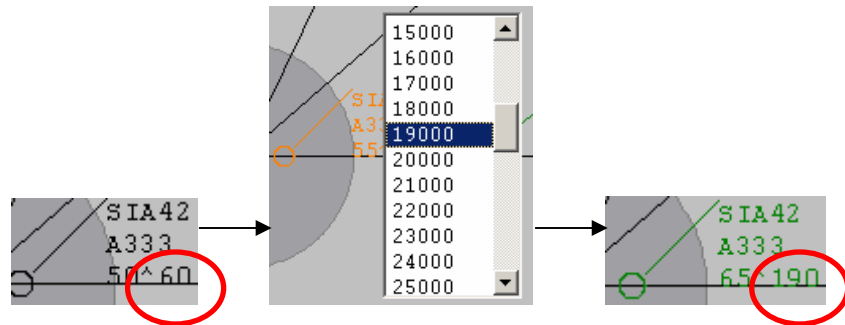

Speed Change

You can change the Speed of an aircraft in intervals of 10 knots.

You will see: A list of possible Speeds will pop up for you to choose from. The aircraft label will read the new chosen speed.

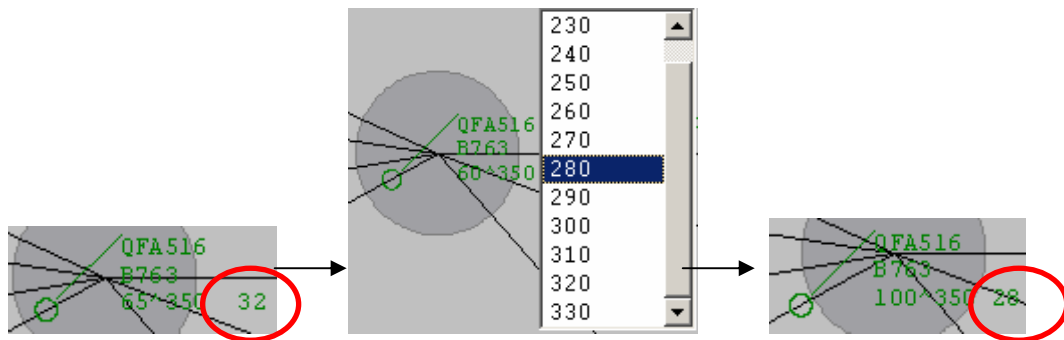

Task 6 – Resolution Options, Continued

Level Requirement by Distance You can issue a Level Requirement to be made by a certain distance. Because there is no acting pilot in the experiment, aircraft will begin climbing or descending at their maximum rate if issued a requirement. The text box however that will pop up when you issue the instruction, will state the level is to be reached within 10nm. For the purposes of the experiment please treat this solution as if the pilot would implement the requirement, even though the program will run the aircraft at it's maximum rate.

You will see: A text box will pop up in which you can type the desired Flight Level. Note that this level needs to be written in **Feet, rather than 100s of Feet**.

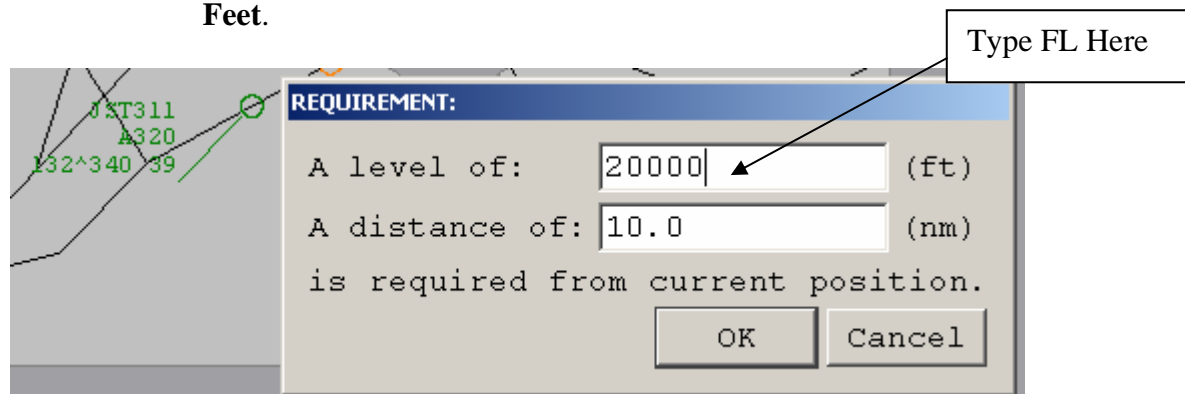

Vector You can change the heading of an aircraft by issuing a vector.

You will see: A green line will represent the vector you draw on the map [1]. A dotted yellow line will follow the aircraft to illustrate the path of its vector [2]. If you decide to vector it back on track you need to draw another green line and direct it towards the yellow route line [3]. A menu may pop up in which you can select the heading for the aircraft.

Note that the yellow route of an aircraft needs to be turned on before you can direct it back to its original track.

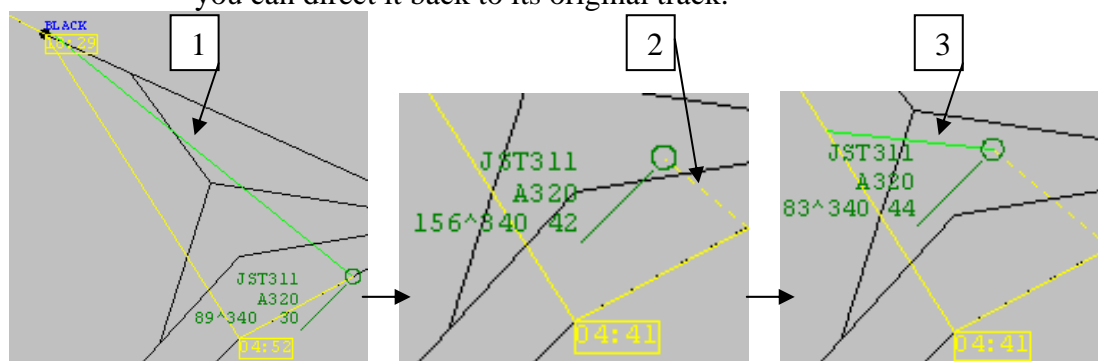

Task 6 – Resolution Options, Continued

When issuing vectors, regular compass headings may be used. Please estimate the heading as accurately as possible when issuing a vector or turn.



Step Climb or Descent

There is no function for a step climb or a step descent itself. You can use this solution by changing levels in steps, as previously shown.

The experimenter may ask you to speak aloud all instructions to pilots and coordination during the experiment.

Instructions Because there is no pilot in the experiment, you may be asked to repeat your instruction aloud (as a pilot would) to simulate the entire time for communication. You can assume that all issued instructions will be accepted and carried out by pilots.

Example: Controller: QFA512 Turn Right Heading 020 degrees.
 Pilot: QFA512 Heading Right 020 degrees.

Coordination There are no controllers managing adjacent sectors, so coordination is artificial. Your experimenter however, may ask you to perform coordination if aircraft are off route.

Task 6 – Resolution Options, Continued

Left Clicks

Solution	Action	Put Back on Track
Level Change	CLICK LEVEL - DOUBLE CLICK TO SELECT Click once on the level in the aircraft label. A list of levels will pop up. Scroll through the list and double click on the level you want.	
Speed Change	CLICK SPEED - DOUBLE CLICK TO SELECT Click once on the speed in the aircraft label. A list of speeds will pop up. Scroll through the list and double click on the speed you want.	
Level Requirement by Distance	L and CLICK - TYPE LEVEL - CLICK OK Press L and click on the track symbol for the aircraft. A text box will pop up. Write your requested level (in feet) in the first white space. Then click “OK”	
Vector	Turn on ROUTE PRESS V then CLICK and DRAG Bring up the route (R and CLICK). Press V, click on the track symbol for the aircraft and drag your vector to where you want.	Turn on ROUTE PRESS V then CLICK and DRAG Bring up the route (R and CLICK). Press V, click on the track symbol for the aircraft, drag and drop it onto the yellow route line
Step Climb or Step Descent	TELL ME and CHANGE LEVELS Please inform the experimenter whenever you decide to implement this solution. Click once on the level in the aircraft label. A list of levels will pop up. Scroll through the list and double click on the level you want.	

Your experimenter will now guide you through implementing each of these resolutions with the software in a practise scenario. You will also get to practise answering the questions.

Thank you for participating in the training course for ATC-lab^{Advanced}. If you have any questions please ask the Experimenter before beginning the experiment.



Notes
